

Linking Economic Model and Engineering Model: Application of Sequential Interindustry Model (SIM)

By

Yasuhide Okuyama, and Hyunwoo Lim

RESEARCH PAPER 2002-12

Yasuhide Okuyama

Regional Research Institute, West Virginia University
511 N. High Street Morgantown, WV 26506-6825 USA

Hyunwoo Lim

Department of Geography, University at Buffalo, The State University of New York
105 Wilkeson Quad, University at Buffalo, Buffalo, NY 14261

Paper presented at the 49th North American Meeting, Regional Science Association International
November 14-16, 2002, San Juan, Puerto Rico.

Abstract: A conventional approach to model the regional economic impacts of a catastrophic disaster has been to employ the results from an engineering model, such as lifeline network model, in an economic model, for example input-output framework or computable general equilibrium model. However, due to the differences in modeling scheme between economic and engineering models, this type of data feed creates problems regarding sensitivity and dynamics of the impacts. In this paper, Sequential Interindustry Model (SIM) is used to disaggregate the process of production chronology to become more sensitive to the changes/damages of economic activities under a disaster situation. SIM is particularly useful to simulate the dynamic processes of impact propagation and of structural changes after a catastrophic disaster. In this paper, the issues and applications of SIM are discussed with numerical examples.

1. Introduction

The damages and losses by disasters, such as earthquakes, floods, tornadoes, and other major natural disasters, or man-made disasters, have significant and intense impacts on a region's economy. In addition, the impacts from the damages will spread over time, and will bring serious economic effects to other regions in a long run. Furthermore, the impacts of disasters are very complex, including not only the negative effects from damages and losses, but also the positive economic effects from the recovery and reconstruction activities. Most economic models and techniques cannot confront these significant changes in a relatively short time period, since they assume incremental, and/or predictable changes in systems over time. And, the unexpected nature of these events, especially in the case of earthquakes, creates a further complication of measuring the indirect impacts (Okuyama *et al.*, 2002). At the same time, most available data for direct damage and losses and of recovery processes are engineering oriented, *i.e.* physical damages and disruption of lifelines and their repair and restoration, and the dimension and unit of these data are quite different from the economic counterpart—very detailed and short time span in engineering data while aggregated and longer time span in economic models. Consequently, these differences pose great challenges in order to model economic impacts of disasters.

While the economic modeling issues for measuring such disruptions and the impacts are more complex (for an excellent summary, see West and Lenze, 1994), the questions of the potential economic effects of a disaster have been studied and discussed in various aspects (for example, Cochrane, 1974; National Science of Academy, 1978; Chang, 1983; Ellson *et al.*, 1984; and Guimaraes *et al.*, 1993, among others). Input-output analysis has been employed in many studies to measure and evaluate the economic impacts of disasters, mainly because of the ability to reflect the structure of regional economy in great detail (for example, Cochrane, 1974, 1995, and 1999; Wilson, 1982; Kawashima *et al.*, 1991; Boisvert, 1992; Gordon and Richardson, 1996; Cole, 1997; Rose *et al.*, 1997; Rose and Benavides, 1998; Okuyama *et al.*, 1999a, among others). Whereas they provide useful information regarding the economic impacts and consequences and about the resource allocation strategies to minimize the losses and impacts, many of these studies have failed to investigate the dynamic nature of impact path over space

and time, due mainly to the difficulties to obtain such data and partly to the static nature of input-output framework.

This is an inherent problem for impact analysis of disasters; as West and Lenz (1994) pointed out, the sophisticated regional impact models requiring precise numerical input have to be reconciled with imperfect measurements of the damages and losses. Moreover, measuring the economic effects of a disaster poses a great challenge for modeling the event *per se* and its consequences—damages and losses occur across various geographical areas and in a relatively short period of time, while the economic effects spread over a larger region (and, sometimes, other regions, too) and, in some cases, may last for a relatively long period of time. In addition, it presents complexities to link a physical/engineering nature of damages and losses with an economic model, in which the degree of details is widely different from direct damage data. Several attempts have been made to combine the engineering data (sometime models) with aggregated economic model. The most common way to connect damages and losses from a disaster and its economic consequences is to directly input the engineering results into an economic model (for example, Rose *et al.*, 1997 and Rose and Benavides, 1998, for modeling the economic impacts of electricity lifeline disruption in Memphis area due to a hypothetical catastrophic earthquake). This approach is relatively simple in terms of modeling strategy and requires less modification to the original models; however, it has no dynamic interactions (feedbacks) between engineering and economic models and it may create problems in terms of sensitivity differences between engineering scenario and economic results.

More engineering oriented approaches (or, hybrid approaches combining engineering model and economic model) to measure the economic effects of a disaster have been implemented in recent years (for example, Chang *et al.* 1999; Okuyama *et al.* 1999b; and Cho *et al.*, 2001). While the connection between engineering and economics components becomes closer and enables feedback between them, these models become either highly aggregated and complex (Okuyama *et al.* and Cho *et al.*) or simple but less flexible in terms of economic component (Chang *et al.*), and have common difficulties in data availability. More comprehensive approach to measure overall impacts of a disaster can be found in HAZUS software developed by National Institute of Building Science. Using the Geographic Information System (GIS) as the user interface, HAZUS includes a wide range of related

modules, from geological and direct physical damage modules to lifeline-utility system and indirect economic losses modules, in order to estimate the effects of a natural hazard in a comprehensive fashion. While the strategy and structure of the indirect economic losses module in HAZUS (see Cochrane, 1997, and 1999 for the details) are similar to Rose *et al.* and Rose and Benavides' models above in the sense that these models employ input-output framework with supply/capacity constraints, it is tailored to deal with smaller geographical areas (county-level) and to include time dimension for more detailed analysis of the recovery process. However, the links between the indirect economic losses module and other engineering modules, such as lifeline-utility systems module, are less clear, and the time dimension implemented in the indirect economic loss module is rather ad hoc¹.

In order for attempting to incorporate with the sensitivity of engineering model/data for the damages and disruptions of a disaster, Sequential Interindustry Model (SIM), introduced by Levine and Romanoff (1989), Romanoff (1984) and Romanoff and Levine (1977, 1981, 1986, 1990a, 1990b, 1991, and 1993) is employed in this study to investigate the dynamic process of the impact paths and recovery process of a disaster while maintaining the simplicity of input-output framework. The SIM framework turns the static framework of standard input-output table into a dynamic formulation, incorporating with production chronology. This framework of SIM is particularly useful to simulate the dynamic process of impact propagation and recovery process after a disaster in short and long runs. Moreover, the SIM provides an opportunity to connect the macroeconomic nature of input-output framework with the microeconomic process of production.

In the next section, a brief discussion of dynamic modeling based on the input-output framework and the analytical framework of SIM are presented and discussed. Section 3 discusses the advantages and issues for adopting the SIM framework to modeling economic impacts of a disaster. In Section 4, the simulation model based on the SIM framework is presented and used for the sensitivity analysis of uncertainty. Finally, Section 5 summarizes and concludes this paper, and addresses some future research needs for linking economic and engineering models.

¹ In HAZUS99 Technical Manual (1999), the time dimension of the indirect economic losses module is described that for the first two months after an earthquake weekly time intervals are used; between two months and 24 months,

2. Modeling Dynamics of Interindustry Production Process: Sequential Interindustry Model

Early interest in the dynamics of interindustry production within the framework of input-output analysis can be seen in Goodwin (1947) and Leontief (1951). These models were expanded by Dorfman, Samuelson, Solow (1958) and Kuenne (1963) and further advanced by Morishima (1964); and, these lines of analysis extended their attention to the integration with linear programming, and/or to Computable General Equilibrium (CGE) modeling to make the model more operational with the specific objective function (linear programming) and to incorporate with more theoretical underpinnings. As a model become more sophisticated, however, the level of aggregation tends to be less detailed and the size of the model becomes larger, especially in the case of CGE models.

As another line of the effort to make the static input-output framework a dynamic model, a dynamic version of input-output model was first introduced by Leontief (1953)² and was modified in his 1970 study (Leontief, 1970). The dynamic input-output model aims to analyze and determine the structural and the technological changes of an economy (or economies) by including an intertemporal mechanism of capital accumulation. Leontief (1970) developed a discrete approximation of model using a system of difference equations with dated technical matrices reflecting structural change in an economy:

$$\mathbf{x}_t = \mathbf{A}_t \mathbf{x}_t + \mathbf{C}_{t+1} (\mathbf{x}_{t+1} - \mathbf{x}_t) + \mathbf{f}_t \quad (1)$$

where $\mathbf{C}_{t+1} (\mathbf{x}_{t+1} - \mathbf{x}_t)$ represents the investment requirements in addition to productive stock during t and $t+1$ in order to expand their capacity output from \mathbf{x}_t to \mathbf{x}_{t+1} . The mathematical properties of this dynamic model have been studied by many (for example, Zaghini, 1971; Schinnar, 1978; de Mesnard, 1992; and Guangzhen, 1993, among others). Leontief's dynamic input-output model has a clear advantage to include the changes in flows and stocks (as a form of capital formulation), and can be suited to incorporate with damages to capital stock (production facilities) and flows (backward and forward linkages) from a disaster. However, the model has

the economy is evaluated on a monthly basis; from two years to 15 years, the economy is evaluated annually.

² In his first model in 1953, Leontief formulated investment as the rate of change in required capital stock using the time derivative of total input vector: $\dot{\mathbf{x}} = \mathbf{A}\mathbf{x} + \mathbf{C}\dot{\mathbf{x}} + \mathbf{f}$.

been used in few empirical works in general due to various problems involved: first, the implementation of the dynamic model requires the assembly of capital requirement matrices that distinguish between replacement and expansion of the capital; and second, the model could produce implausible results due to its structure³.

Based on a different approach to introduce a dynamic structure in the static input-output framework, a group of lagged input-output models with distributed activities were proposed (for example, ten Raa, 1986; and, Cole, 1988 and 1989). Concerning the time used in production process and taking into account the time of labor market adjustment, among other things, these lagged input-output models aim to capture the process of impact (or growth) from a production expansion within the input-output framework. The distributed activity model developed by ten Raa (1986) is based on the formulation of the Leontief's dynamic input-output model, solving some of the drawbacks in that framework (singular capital structures, unbalanced growth, and different time profiles of investment) while preserving the formal structure and simplicity of the original Leontief dynamic model. Ten Raa's model is highly theoretical and aggregated, and few practical applications based on his formulation have been implemented. On the other hand, Cole's models (Cole, 1988 and 1989) are highly operational⁴ and are based on the empirical examples of western New York and of Aruba. While Cole's approach is highly practical for simulation type analysis, some theoretical and structural issues⁵ of them need to be addressed in

³ Leontief (1970) implemented his dynamic model using 1947 and 1958 US data, and it revealed the two major inherent drawbacks of the model, which could produce implausible results. Leontief solved the model employing the backward-looking way--determine the final impacts first, and then solve the model for the requirements in previous years. This backward-looking solution is stable, yet unrealistic, since it assumes that the economy has a perfect foresight of the future. Although the forward-looking solution has been studied [Szyld (1985), Steenge (1990a), Heesterman (1990), and Steenge (1990b)], it has been found that a set of non-negative solutions for \mathbf{x}_t exists only if the initial conditions lie on the "balanced growth path". This drawback comes from the assumption of full capacity utilization: the entire physical productive capacity will be utilized. Another difficulty to derive the solution of the Leontief dynamic model is the singularity of the capital matrix, \mathbf{C} . As Duchin and Szyld (1985) pointed out, most theoretical works have been carried out based on the assumption that the \mathbf{C} matrix is invertible, whereas the \mathbf{C} matrix may be invariably singular, with rows of zeros corresponding to the sectors not producing durable goods. In order to overcome these problems, Duchin and Szyld (1985) proposed the new formulation of the dynamic input-output model, and this formulation was used in Leontief and Duchin (1986) study. More recently, Campisi and his colleagues developed a series of models based on the Duchin-Szyld formulation, with an extension to multiregional context, and applied to the Italian economy (Campisi *et al.*, 1990; Campisi, Nastasi, and Bella, 1992; and Campisi and Nastasi, 1993).

⁴ Some numerical examples for his models are presented in his 1997 paper (Cole, 1997) with some insights to further extend the input-output framework.

⁵ Extensive discussions were made regarding the theoretical underpinning and the formulation of Cole's models in Jackson *et al.* (1997), Cole (1997), Jackson and Madden (1999), Cole (1999), and Oosterhaven (2000).

order to be employed in more complicated application, such as this study. As a similar approach but with more emphasis on production chronology, Romanoff and Levine introduced the Sequential Interindustry Model (SIM) in order to incorporate more engineering aspect of production process. In the following part, SIM is presented and discussed.

Sequential Interindustry Models

Levine and Romanoff (1989), Romanoff (1984), and Romanoff and Levine (1977, 1981, 1986, 1990a, 1990b, 1991, and 1993) introduced the Sequential Interindustry Model (SIM) in response to the need to analyze interindustry production in a dynamic economic environment, such as large construction projects where the effects on production and employment are transitory. Assuming for simplicity that time is divided into discrete intervals of equal duration, the SIM enhances the static input-output model to the dynamic one by supplementing the structure of production with a production chronology. In the SIM, production is not simultaneous as in the static input-output model, but rather occurs sequentially over a period of time (Romanoff and Levine, 1981). The interval of an industry production process is divided into two components: the production interval and the shipment interval with inputs and product inventories, as illustrated in Figure 1. In order to create the dynamics of SIM, a distinction is made among three events in a production process: demand stimulus occur when goods are ordered; yield or supply happens when goods are delivered; and production yield occurs when goods are produced. In SIM, demand is not restricted to final demand but includes intermediate demand along the production sequences, as in the standard input-output framework. Final demand stimulus is the ultimate system input, while final yield or final supply is the net system output.

<< *Insert Figure 1 here* >>

Determining the dynamics of interindustry production, two simplified production modes are proposed: *anticipatory production* mode and *responsive production* mode. The anticipatory production mode is typical in agriculture and many manufacturing industries, in which the production is made in anticipation of future orders. In this mode, producers' specifications result in ready-made standards products and in holding product inventory. On the other hand, responsive production takes place after the receipt of orders, responding to customers'

specification by producing to meet the unique requirements, while product inventory is unlikely. This production mode is typical of some manufacturing, most of construction and ordnance industries, and most of services industries⁶ (Romanoff and Levine, 1981, and 1986).

In the time-varying SIM, some specific time indices are defined (Romanoff and Levine, 1990). These are given in parentheses and pertain to production technique in use and to temporal events or intervals. The time indices are:

- t : time interval of input application;
- σ : time interval of output or production completion;
- h_{ij} : application period of an input from industry i used by industry j , referenced from the initial application interval t , to product completion σ ;
- h_j : production period of industry j , equivalent to the longest application period among h_{ij} ;
- $t - \sigma$: input duration, indicating the period from an input application interval t to the time of output completion, σ , measured backwards in time from σ (equal or longer than h_j); and
- ϕ_{ij} : transportation delay associated with the shipment from industry i to industry j , representing the components of the transportation delay matrix, Φ .

The relation between these time indices and production interval (process) is shown in Figure 2.

<<Insert Figure 2 here>>

Anticipatory Production Mode

Assuming just-in-time production on the input side (no input inventory), the input price from industry i to j is given by $p_i(t - \phi_{ij})$, since the input price is determined at the time that it leaves supplying industry i . The quantity of input from i to j is defined as $q_{ij}(\mu_{t,ij}; t, \sigma)$,

⁶ Most of services industries can be considered as *just-in-time production* mode, in which the production takes place and the goods delivered, as the order is placed—less time is needed for production comparing to manufacture and construction industries. However, just-in-time production mode can be considered a special case of responsive production mode when ordering lead time and production interval are minimal, as shown in later part of this section.

processed by technology μ at time t in industry j using input from i in order to complete the product at σ . The value of transaction from i to j is:

$$x_{ij}(\mu_{t,ij}; t, t - \phi_{ij}, \sigma) = p_i(t - \phi_{ij}) \cdot q_{ij}(\mu_{t,ij}; t, \sigma) \quad (2)$$

The total output of industry j , x_j , completed at σ is priced at the time of product completion for anticipatory production mode is:

$$x_j(\sigma, \sigma) = p_j(\sigma) \cdot q_j(\sigma) \quad (3)$$

where $q_j(\sigma)$ is the quantity of output produced by j at σ . Using (2) and (3), the time-phased technical coefficients can be derived as follows:

$$a_{ij}(\mu_{t,ij}; t, t - \phi_{ij}, \sigma, \sigma) = \frac{x_{ij}(\mu_{t,ij}; t, t - \phi_{ij}, \sigma)}{x_j(\sigma, \sigma)} \quad (4)$$

Romanoff and Levine (1990) claims that the coefficients represent the relative costing out of i for the production process of the schedule of j ; thus, in equilibrium, the coefficients sum to the technical coefficient in the static input-output framework over time for each i .

Total intermediate output produced by industry i becomes:

$$w_i(t, t) = \sum_{\sigma} \sum_j \sum_{\mu} a_{ij}(\mu_{t,ij}; t, t - \phi_{ij}, \sigma, \sigma) \cdot x_j(\sigma, \sigma) \quad (5)$$

which is a generalized convolution indicating the dynamics of intermediate production. Then, the accounting identity of industry i will become as follows:

$$x_i(t, t) = \sum_{\sigma} \sum_j \sum_{\mu} a_{ij}(\mu_{t,ij}; t, t - \phi_{ij}, \sigma, \sigma) \cdot x_j(\sigma, \sigma) + u_i(t, t) + y_i(t, t) \quad (6)$$

where $u_i(t, t)$ is the output to product inventory (adjusting the differences between anticipated output level and demand level) and $y_i(t, t)$ is the final demand for industry i . Using matrix notation, Equation (6) becomes:

$$\mathbf{x}(t, t) = \sum_{\sigma} \mathbf{A}(\mathbf{M}; t, t - \phi_{(\cdot)}, \sigma, \sigma) \cdot \mathbf{x}(\sigma, \sigma) + \mathbf{u}(t, t) + \mathbf{y}(t, t) \quad (7)$$

where \mathbf{M} is the technology matrix, and $\phi_{(\cdot)}$ indicates the appropriate elements of the transportation delay matrix, Φ . This formulation is a formally specified version of their simpler

version SIM (called Core SIM) presented in Romanoff (1984) and Romanoff and Levine (1981), with an exception of inventory. If the function of inventory is included in Core SIM, it will become, in anticipatory production mode:

$$\mathbf{x}_t = \mathbf{A}\mathbf{x}_\sigma + \mathbf{u}_t + \mathbf{y}_t \quad (8)$$

The major assumption in terms of inventory is that, unlike final demand that is exogenous of the system, inventory is an endogenous function based on inventory policies of anticipatory producer. In this regard, Romanoff and Levine (1990 and 1991) excluded the discussion on analysis of inventory management in SIM⁷.

Responsive Production Mode

While producers' price, $p_i(t - \phi_{ij})$, may be better suited for anticipatory producers, they may also be applicable to responsive producers (Romanoff and Levine, 1990). Therefore, Equation (2) holds also for responsive production mode. What make responsive production mode different from anticipatory mode is in the time of output pricing, *i.e.*, for responsive producers, the price of output is determined when an order is issued. Hence, this ordering lead time, ε_j , is set ahead of beginning of the production interval, h_j from the production completion at σ . Then, the total output of industry j becomes:

$$x_j(\sigma, \sigma - h_j - \varepsilon_j) = p_j(\sigma - h_j - \varepsilon_j) q_j(\sigma) \quad (9)$$

Consequently:

$$a_{ij}(\mu_{t,ij}; t, t - \phi_{ij}, \sigma, \sigma - h_j - \varepsilon_j) = \frac{x_{ij}(\mu_{t,ij}; t, t - \phi_{ij}, \sigma)}{x_j(\sigma, \sigma - h_j - \varepsilon_j)} \quad (10)$$

The total output of responsive production mode is:

$$x_i(t, t - h_j - \varepsilon_j) = \sum_\sigma \sum_j \sum_\mu a_{ij}(\mu_{t,ij}; t, t - \phi_{ij}, \sigma, \sigma - h_j - \varepsilon_j) \cdot x_j(\sigma, \sigma - h_j - \varepsilon_j) + y_i(t, t - h_j - \varepsilon_j) \quad (11)$$

⁷ Romanoff and Levine (1990) included some discussions about inventory modeling in SIM and pointed to their 1977 paper for more discussion; however, at the time of writing, their 1977 paper was not available.

Note that responsive production mode is, of its nature, without production inventory⁸. The corresponding matrix form is:

$$\mathbf{x}(t, t - h_j - \varepsilon_j) = \sum_{\sigma} \mathbf{A}(\mathbf{M}; t, t - \phi_{(\cdot)}, \sigma, \sigma - h_j - \varepsilon_j) \cdot \mathbf{x}(\sigma, \sigma - h_j - \varepsilon_j) + \mathbf{y}(t, t - h_j - \varepsilon_j) \quad (12)$$

This formulation can also be compared to a simpler version in Core SIM, and corresponding responsive production mode in Core SIM can be re-written as:

$$\mathbf{x}_t = \mathbf{A}\mathbf{x}_{\sigma-h-\varepsilon} + \mathbf{y}_t \quad (13)$$

Combined Anticipatory-Responsive Production Model

Since the input-output model is on interindustry framework, it is natural to assume that anticipatory production and responsive production industries are coupled with each other in the model. The anticipatory production mode in (7) and the responsive production mode in (12) are distinguished in a way that the anticipatory mode does not require ordering lead time ($h_j + \varepsilon_j = 0$), whereas the responsive mode does not include the production inventory ($\mathbf{u}(\cdot) = \mathbf{0}$). Therefore, the combined anticipatory-responsive model encompasses both properties as follows:

$$\mathbf{x}(t, t - h_j - \varepsilon_j) = \sum_{\sigma} \mathbf{A}(\mathbf{M}; t, t - \phi_{(\cdot)}, \sigma, \sigma - h_j - \varepsilon_j) \cdot \mathbf{x}(\sigma, \sigma - h_j - \varepsilon_j) + \mathbf{u}(t, t) + \mathbf{y}(t, t - h_j - \varepsilon_j) \quad (14)$$

While this version of SIM combines the anticipatory mode and responsive production mode industries, each industry is classified into one of the production modes. In the real world, some industries may produce their goods using a combination of these modes (for example, computer manufacturing industry that produces both pre-configured (with anticipation) and customer-configured (by taking orders) computers). Although this type of details becomes important in an analysis of specific industries, with the aim of modeling in a regional context, it is beyond the scope of this study.

⁸ For responsive production mode, it is more likely to have input inventory; however, in this formulation (Romanoff and Levine, 1990), assuming just-in-time production for simplicity, input inventory is not considered in either mode. However, the production inventory of anticipatory industries can work as the input inventory for responsive industries, although it may not fully reflect the complexity of real world production process.

3. Issues of SIM for Modeling Economic Impacts of Disasters

In this section, modifications and extensions of SIM to link closer with engineering model are proposed and discussed. In addition, some of the issues of modeling economic impacts of disasters, such as uncertainty, technology replacement, and inventory, are discussed for the use of the Sequential Interindustry Model (SIM).

Compatibility with Engineering Models

Originally, Sequential Interindustry Model (SIM) was developed by supplementing the structure of production with production chronology (Romanoff and Levine, 1981). This inclusion of production chronology in the static input-output framework made possible to analyze lagged impacts, such as labor market expansions and man power issues (Romanoff, 1984). Production process, especially for most of manufacturing industries, is well represented in this SIM framework (with anticipatory production mode), and the framework was used in evaluating the impacts of large construction projects for its lagged impacts (with responsive production mode; Romanoff and Levine, 1990a). This close representation of production scheduling made SIM coupled with engineering project scheduling methods, such as Critical Path Method (CPM) in order to analyze the dynamic economic impacts of a large, complex, and lengthy production, construction, and related macroengineering undertakings (Levine and Romanoff, 1989). This feature of SIM is particularly useful and effective to model the dynamic process of recovery and reconstruction activities after a disaster. The version of SIM presented in the paper is especially valuable for incorporating with various time schedule of production process (input application period, product completion period, order lead time, and transportation delay), production technology, and inventory, which may be different from before and/or may be fluctuating after a disaster.

While SIM can deal well with engineering information regarding production scheduling and transportation delay, other engineering losses, such as disruption and/or fluctuation of lifelines, can be handled as capacity constraints. In the standard input-output framework, capacity constraints can be imposed as supply constraint (shock) by rebalancing transaction matrix as in Cochrane (1997, and 1999) or by deriving final demand change from potential

output reductions as in Rose *et al.* (1997) and Rose and Benavides (1998). Romanoff and Levine (1986) studied the capacity limitations with the use of inventory in the SIM framework; however, the formal representation of capacity limitation in their modified SIM was not explicit. Another characteristic of lifeline losses is that the duration of the outages might be quite short, especially for power outage (a few weeks for full recovery of the entire system at longest), and it can be shorter than the production duration in the SIM framework for most industries. Although some industries have a very short production period, the major assumptions⁹ of and the nature of SIM make difficult to incorporate with such short and fluctuating changes. In this sense, SIM may need to be modified further to integrate with the damage data sensitive to a very short time period.

Uncertainty

One of the less-emphasized aspects in modeling economic impacts of a disaster is that the occurrence and the consequences involve uncertainty. For example, the occurrence of the event is usually unpredictable, especially in the case of earthquakes, and this unpredictability creates a surprise effect for anticipatory production industries (Okuyama *et al.*, 2001). This surprise factor can be further analyzed with the inventory function in the SIM framework; for example, whether or not the built-up product inventory, which is suddenly realized right after the event, can be offset by the influx of demand injections for recovery and reconstruction activities over time, or how the damages and/or capacity limitation of product inventory can affect the production level after the event.

Uncertainty after a disaster can be also dealt within the SIM framework. Uncertainty arises after a disaster, because: first, the extent and range of direct damages are unknown right after the event; second, the trends of economic activities, especially the fluctuation of demand, become unclear in a short run; and, third, the influx of demand injections for recovery and reconstruction activities makes the long run forecast (anticipation) of economic growth in the region difficult. These uncertainties after a disaster can be adopted in the SIM framework in the

⁹ Romanoff and Levine (1981) stated that two aspects of production interval are essential to the formulation of SIM: 1) the industry production interval is the same for all industries and remains constant in time; and, 2) all industry production intervals are synchronized. Although the first assumption of fixed production intervals are relaxed in their later model (Romanoff and Levine, 1986; the formal representation is not clear, though), the second assumption remains essential all versions of SIM.

way that some of the anticipatory production industries may not be able to anticipate the future intermediate demand stream and may decide the production level based on the current demand level. Because of the difficulty to anticipate the future intermediate demand, the production inventory need play an important role. On the other hand, while the recovery and reconstruction schedule will be likely available and these activities may become a large part of the economic activities for a while after the disaster, the degree of uncertainty over time requires a careful treatment.

Technology Replacement

Damages and losses from a disaster may become significant to the older structures and facilities. These older structures and building are often equipped with older machines and production lines. Or, even in newer buildings and facilities, older equipments may be damaged due to the mechanical fatigue of equipments. After the disaster and during the recovery stage, these damaged equipments and production facilities are most likely replaced with new ones with newer technology. Although these technology replacements may not take place all the facilities within a particular industry in the region, different from technological progress in a specific industry, it may become significant if the area with a disaster includes the concentration/cluster of a particular industry (for example, Chemical Shoes Industry located in Nagata Ward, Kobe in the Kobe Earthquake).

Within the SIM framework presented in the previous section, this technology replacement is reflected in the time variant technology, $\mu_{t,ij}$, and thus, the technical coefficient also becomes time variant, $a_{ij}(\mu_{t,ij}; t, t - \phi_{ij}, \sigma, \sigma - h_j - \varepsilon_j)$ in the combined model presented in Equation (14). Romanoff and Levine (1990) discussed the issue of technical change in the SIM framework, with a simple example of “*pure technical replacement*” using a logistic function as the transition process. While the logistic curve of technology transition is plausible under the normal circumstances of economic growth, in a disaster situation technology replacement may become rather arbitrary and exogenous of production schedule, depending mainly on the availability and schedule of replacement funds (insurance and/or savings). In the current version of SIM, this technology replacement can be handled with the manipulation of time variant

technology, $\mu_{t,ij}$, and its sensitivity analysis in terms of replacement timing may lead to some policy implications for the recovery and reconstruction process.

Inventory

One of the criticisms against the SIM framework is its “perfect knowledge” assumption (Mules, 1983), in which each sector is aware of both the direct and indirect demands made upon it as a result of any given initial impact. Romanoff and Levine responded to include the inventory for the adjustment between anticipated demand and actual orders (Romanoff and Levine, 1990 and 1991). This inventory is useful and more realistic than the perfect knowledge assumption, and the product inventory, $\mathbf{u}(t,t)$, is a function of the different inventory strategy among anticipatory industries (Romanoff and Levine, 1990). This function of inventory in the SIM framework is particularly useful under a disaster situation. As indicated in the discussion of uncertainty, product inventory becomes a key to analyze the surprise factor of an unexpected disaster and to investigate its adjustment role for the influx of demand injections for recovery and reconstruction activities. In addition, some disasters may damage the inventory facilities; and, the analysis on the impacts of damaged inventory becomes possible with the SIM framework.

However, this function of product inventory needs to be treated carefully in terms of its modeling structure. A product flow to the product inventory occurs when the anticipated demand and actual orders/shipments do not match¹⁰. However, the anticipated demand is used only for the production of intermediate goods; therefore, the following relationship should hold:

$$\mathbf{A}\mathbf{x}_\sigma + \mathbf{u}_t = \mathbf{A}\hat{\mathbf{x}}_\sigma \quad (15)$$

where \mathbf{x}_σ is the actual orders/shipments at σ and $\hat{\mathbf{x}}_\sigma$ is the anticipated demand for σ at t . However, an inherent problem of input-output framework arises in this equality: since input-output framework is a flow (transaction) model, it does not include the concept of stock—accumulation of flows. And, inventory is a stock—accumulation of flows to the inventory including carry-over from the previous period. The product inventory, \mathbf{u}_t , is the flow to the

¹⁰ This is a narrow definition of product inventory. Some industries always keep a particular level of inventory as a part of the production strategy.

product inventory at t ; therefore, when actual order/shipment level, \mathbf{x}_t , is larger than the anticipated demand level, $\hat{\mathbf{x}}_t$, some of the elements in \mathbf{u}_t may become negative value. This creates the problem in a flow model (while the equality of the formulation holds, there is no indication of actual inventory level); however, this is plausible in the stock model—the inventory level becomes lower due to the greater orders than anticipated/produced. In this regard, the SIM framework needs to be further modified to incorporate with inventory stock.

4. SIM and Simulation

The theoretical formulations of SIM have been presented and discussed in the previous sections. Numerical examples are still useful to illustrate how the model works and how sensitive the model is for a particular variable (or variables). SIM has been presented with numerical simulations (Levine and Romanoff, 1989; Romanoff, 1984; and, Romanoff and Levine, 1981, and 1986), although the results from and the analysis of numerical examples and simulations require a careful treatment¹¹. In this section, a simple example used in Romanoff (1984) is employed for constructing a simulation model using systems analysis technique. Once constructed, the simulation model is used to analyze the sensitivity of uncertainty after a disaster.

Example Based on Romanoff 1984

In this sub-section, a simple example employed in Romanoff, 1984 is introduced for creating a simulation model based on it. Consider a simple one-region three-sector input-output model which has the transaction table shown in Figure 3 (the matrices of direct input coefficients and Leontief Inverse are presented in Appendix, A-1). In this example, Sectors 1 and 2 are considered as anticipatory mode production, in which Sector 1 anticipates the intermediate demand from Sector 2 one period ahead and anticipates the intermediate demand from Sector 3 two periods ahead, while Sector 2 anticipates Sector 3's intermediate demand one period ahead (the production chronology (production digraph) is shown in A-2). For simplicity, the final

¹¹ Jackson and Madden (1999) warned the hazards of over-reliance on box-diagram conceptual frameworks and simulations in the absence of formal specifications, in response to Cole's presentation of his models (Cole, 1997).

demand schedule is set as constant over time if no disaster occurs. The unit of time can be a month, a quarter, or a half-year.

<<Insert Figure 3 here>>

For analyzing the trends of economic impacts of a disaster, the hypothetical scenario is set that a catastrophic disaster occurs in the beginning of the 5th period, and that final demand in each sector decreases 20% from the previous level and will start to regain at 3% increase from the previous level per period from 6th period as the recovery and reconstruction activities progress. The final demand schedule is shown in Table 1. In addition, due to the uncertainty for anticipating the future trends imposed by the disaster, the anticipatory mode sectors (Sectors 1 and 2) might adjust their anticipation practice to shorter period than before. In this example, for production during Period 5, all the sectors can hardly foresee/anticipate the future demand schedule; therefore, it is assumed that they will anticipate the demand only the following period. Likewise, for the production in Period 6, the anticipatory sectors can only anticipate one period further. From the production during Period 7, the anticipation of the future demand stream returns to the usual practice before the disaster. Based on these assumptions, the estimated output level over time is shown in Table 2 (more details and further discussion on this example can be found in Okuyama *et al.*, 2001).

<<Insert Tables 1 and 2 here>>

Simulation Model with Inventory

The version of SIM used in Romanoff's example (Romanoff, 1984) presented above is the Core SIM without the function of inventory for anticipatory production sectors in the extended SIM illustrated in the previous section of this paper. The function of inventory becomes particularly important after a disaster, as discussed in Section 3. In addition, input-output framework is basically a flow model, while the function of inventory is considered as a stock. Thus the model used in the above example is transformed to a simulation modeling including an inventory capability using systems analysis framework. The systems analysis framework, especially based on the Forrester-type system dynamics (Forrester, 1968), is useful to model the changes in a dynamic system using both flow and stock functions.

Using programming software, Stella, the model with inventory is developed as shown in the diagram, Figure 4. Here, the production level of each sector, p_i , is determined by the final demand, y_i , and anticipated intermediate based on the anticipated demand, $y_{j,tk}$, to sector j . Then, completed products go in to the inventory¹², X_i , and consumed at the level of $X_{i,out}$. Because of the possible error made in anticipating the future final demand by Sectors 1 and 2, the difference between the production level and consumed level are calculated imposing random error terms ($errorT1$ and $errorT2$, error term for one period anticipation and for two-period anticipation, respectively). These error terms are either positive or negative (overestimation or underestimation of future demand) and are applied to Sectors 1 and 2 ($errorT1$ and $errorT2$ for Sector 1 and $errorT1$ for Sector 2).

<<Insert Figure 4 here>>

Sensitivity of Uncertainty to Inventory

To investigate how uncertainty plays the role after a disaster in terms of inventory control in anticipatory sectors, the following three scenarios are presented for sensitivity analysis:

Scenario A: Before the disaster, the inaccuracies of anticipation over one period and over two periods are set $\pm 2.5\%$, $\pm 5\%$, respectively; in Period 5, right after the event occurs, the inaccuracies increase up to $\pm 20\%$ and $\pm 40\%$; then, the anticipation of future demand streams is somewhat improved after Period 6 but still not as good as before the event, and the inaccuracies are set $\pm 5\%$ and $\pm 10\%$.

Scenario B: The inaccuracies of anticipation over one period and two periods are the same as in Scenario A before the event and after Period 6; the inaccuracies in Period 5 are improved than in Scenario A, to $\pm 10\%$ and $\pm 20\%$, respectively.

Scenario C: The inaccuracies during Period 5 further improve, now at $\pm 5\%$ and $\pm 10\%$, respectively; the inaccuracies of other periods are the same as in Scenarios A and B.

¹² Since Sector 3 is not an anticipatory production mode, Sector 3 should not have the inventory; however, due to the modeling rule in Stella, the box, X_3 , needs to be placed. X_3 is always cleared at each period.

The initial inventory levels of Sectors 1 and 2 are set 2 units and 1 unit, respectively, indicating that since Sector 1 anticipates further ahead, the larger inventory capacity is necessary to accommodate the wider degree of fluctuation between anticipated and actual demand levels. Each scenario was run 30 times, and the average and standard deviation of the inventory level over time for Sectors 1 and 2 are calculated.

Figures 5 and 6 show the trends of average and standard deviation of inventory level over 30 simulation runs under Scenario A. In volume term, the inventory levels for both Sectors 1 and 2 jump up¹³ at Period 5 when the disaster occurs, and fluctuates but becomes steady after that in both inventories. The standard deviations of both inventory levels display the similar trends to the average. At Period 5, the standard deviations significantly increase, due to the uncertainty thus a large gap between anticipated and actual levels. After Period 6, the standard deviations fluctuate and have the trend of slight increase. Sector 1's inventory (Inventory 1) has a larger increase than Sector 2's at Period 5 and, in general, larger standard deviations throughout, due to the fact that Sector 1 anticipates further (two periods ahead) and that creates a larger variation in mis-anticipation level.

<<Insert Figures 5 and 6 here>>

Under Scenario B, the trends of averages and standard deviations become more stable (Figures 7 and 8). For the trends of average, there are no significant jumps at Period 5 for the trends of average; this may be because the larger number of lower bound simulation results are included because of more accurate anticipation (lower inaccuracy rate at Period 5). There are significant jumps at Period 5 for the trends of standard deviation, and, after Period 6, the standard deviations tend to increase, especially for Sector 1. This steady increase in inventory level is rather inherent in the current model, since there is no inventory management strategy is programmed in this version.

<<Insert Figures 7 and 8 here>>

¹³ This is due to the fact that the inventory level cannot become negative value in the model. If the actual demand is larger than the sum of anticipated demand/production and the current inventory level, it will cause the supply constraint to the forward linkage industries; however, in this version of simulation model, there is no mechanism that can distribute the limited number of products under the supply constraint situation. Therefore, only the simulation results in which the inventory level remains positive value are used for this display, indicating upper bound results.

In Scenario C, which has less uncertainty is assumed, the trends in Figure 9 and 10 become much smoother for both average and standard deviation. Unlike in Scenarios A and B, there is no significant increase at Period 5; only slight increase in slope for the standard deviations of the inventory level for Sectors 1 and 2. The inventory levels are steady throughout the periods, indicating more accurate anticipation.

<<Insert Figures 9 and 10 here>>

Although these scenarios are rather simple, the role of information (uncertainty) after a disaster is revealed important; if the future version of the model includes the inventory management strategy and feedback mechanism to production process, and imposes the supply constraints for forward linkage sectors in the case of inventory exhaustion, it may derive a more accurate picture of the impacts to production process and of overall economic impacts.

5. Summary and Conclusions

In this paper, the Sequential Interindustry Model (SIM) framework is examined and discussed in order for the use in modeling economic impacts of disasters. Because of its dynamic structure and adoption of production chronology, SIM can deal with many issues that other economic models may not, such as uncertainty, technology replacement, and inventory. The SIM framework also has more potential to link with engineering data and models for the damages and losses, since its original intents aims very closely to the evaluation of engineering processes and projects. Although further theoretical development is necessary, especially for the formal representation of inventory function and its strategy and for the adoption to the situations of demand/supply constraint, the SIM framework is flexible enough to deal with many different situations and scenarios in an empirical context.

In order to further examine the economic impacts of disasters, the SIM framework has the potentials to cope with engineering models/data with further modifications. The most promising potential of the SIM framework is to analyze the process of recovery and reconstruction process. Since SIM was originally developed for evaluating large construction projects (Romanoff and Levine, 1990), the structure of SIM is suited to examine the rapid and

intense process of recovery and reconstruction after a disaster. With a successful determination of inventory function, SIM can simulate the case of supply constraints under the influx of recovery activities (shortage of construction material, etc.) and can evaluate the labor market adjustment process (a large increase in labor supply during the recovery and reconstruction and sudden decrease after the completions). The analysis of uncertainty after a disaster is also an important issue that SIM can handle well. The simulation model constructed in this paper can be modified to use an empirical input-output data with a little effort, while the assignment of production mode across the industries and the determination of different inventory management strategies among anticipatory industries may pose some difficulties with more detailed data requirement.

Directly connecting SIM with engineering models, such as lifeline network models, may be a difficult task, because the SIM framework is still considered as too aggregated in a sense that SIM cannot response to the damages of each factory in a region. In order to connect SIM, probably indirectly, with engineering models and data, some interface module bridging SIM and engineering counterpart is necessary. In the interface module, economic activities, of particular key industries, need to be modeled in order to be compatible with the dynamics of engineering process. Using this interface module, SIM can analyze the critical timing/schedule of recovery process in terms of production chronology and interindustry relationship to minimize demand-supply mismatch, hence decrease the indirect economic impacts, among industries under a disaster condition.

Acknowledgement

This research was supported by the National Science Foundation, Award CMS-0099724. The authors are grateful to the encouragements and comments from Eliahu Romanoff and Stephen Levine, and to the comments given at the 14th International Conference on Input-Output Techniques at Montreal, Canada in 2002.

References

- Boisverst, Richard. (1992) "Indirect Losses from a Catastrophic Earthquake and Local, Regional, and National Interest," in *Indirect Economic Consequences of a Catastrophic Earthquake*, Washington, D.C.: National Earthquake Hazards Reduction Program, Federal Emergency Management Agency: 207-265.
- Campisi, Domenico. and Alberto Nastasi. (1993) "Capital Usage and Output Growth in Multiregional Multisectoral Models: An Application to the Italian Case," *Regional Studies*, 27 (1): 13-27.
- Campisi, Domenico., Alberto Nastasi, and Agostino La Bella. (1992) "Balanced Growth and Stability of the Leontief Dynamic Model: An Analysis of the Italian Economy," *Environmental and Planning A*, 24 (4): 591-600.
- Campisi, Domenico., Agostino La Bella, Massimo Gastaldi, Bruna Ludovici, and Gustav Schachter. (1990) "A Multi-Regional Multi-Sectoral Input-Output Model for Italy," in Luc Anselin and Moss Madden ed. *New Directions in Regional Analysis*, New York, NY: Belhaven Press, 187-210.
- Chang, Semoon. (1983) "Disasters and Fiscal Policy: Hurricane Impact on Municipal Revenue," *Urban Affairs Quarterly*. 18 (4): 511-523.
- Chang, Stephanie E., M. Shinozuka, and W. Svekla, (1999) "Modeling Post-Disaster Urban Lifeline Restoration," in *Proc. 5th U.S. Conference on Lifeline Earthquake Engineering*, Seattle, WA, August 1999.
- Cho, Sungbin., Peter Gordon, James E. Moore II, Harry W. Richardson, Masanobu Shinozuka, and Stephanie Chang. (2001) "Integrating Transportation Network and Regional Economic Models to Estimate the Costs of a Large Urban Earthquake," *Journal of Regional Science*, 41 (1): 39-65.
- Cochrane, Harold C. (1974) "Predicting the Economic Impacts of Earthquakes," in Harold C. Cochrane, J. Eugene Haas, Martin J. Bowden, Robert W. Kates eds. *Social Science Perspectives on the Coming San Francisco Earthquake*, Natural Hazards Research Paper No. 25, NHRAIC, Boulder: University of Colorado.
- Cochrane, Harold C. (1995) "Forecasting the Economic Impact of a Midwest Earthquake," in Barclay G. Jones ed. *Economic Consequences of Earthquakes: Preparing for the Unexpected*. Buffalo, NY: National Center for Earthquake Engineering Research: 223-247.
- Cochrane Harold C. (1999) "Indirect Economic Losses," in *Earthquake Loss Estimation Methodology: HAZUS99 Technical Manual, Volume 3*. Washington D.C.: Federal Emergency Management Agency: 16-1 – 16-63 (http://www.fema.gov/hazus/dl_tech3.pdf).

- Cole, Sam. (1988) "The Delayed Impacts of Plant Closures in a Reformulated Leontief Model," *Papers in Regional Science Association*. 65: 135-149.
- Cole, Sam. (1989) "Expenditure Lags in Impacts Analysis," *Regional Studies*. 23 (2): 105-116.
- Cole, Sam. (1997) "Decision Support for Calamity Preparedness: Socioeconomic and Interregional Impacts," in M. Shinozuka, A. Rose, and R.T. Eguchi eds. *Engineering and Socioeconomic Impacts of Earthquakes*. Buffalo, NY: Multidisciplinary Center for Earthquake Engineering Research: 125-153.
- Cole, Sam. (1997) "Closure in Cole's Reformulated Leontief Model: A Response to R.W. Jackson, M. Madden, and H.A. Bowma," *Papers in Regional Science*. 76 (1): 29-42.
- Cole, Sam. (1999) "The Phantom of the Matrix: Inverting the Case on Closure in Cole's Model," *Papers in Regional Science*. 78 (4): 429-436.
- de Mesnard, Louis. (1992) "The Asynchronous Leontief Model," *Economic Systems Research*, 4 (1): 25-34.
- Dorfman, R., P.A. Samuelson, and R.M. Solow. (1958) *Linear Programming and Economic Analysis*. New York, NY: McGraw Hill.
- Duchin, Faye. and Daniel B. Szyld. (1985) "A Dynamic Input-Output Model with Assured Positive Output," *Metroeconomica*, 37 (3): 269-282.
- Ellson, Richard., Jerome W. Milliman, and R. Blaine Roberts. (1984) "Measuring the Regional Economic Effects of Earthquakes and Earthquake Predictions," *Journal of Regional Science*. 24 (4): 559-579.
- Forrester, Jay W. (1968) *Principles of Systems*, Cambridge, MA: Wright-Allen Press.
- Goodwin, R.M., (1947) "Dynamical Coupling with Especial Reference to Markets Having Production Lags." *Econometrica* 15: 181-204.
- Gordon, Peter., and Harry Richardson. (1996) "The Business Interruption Effects of the Northridge Earthquake," Lusk Center Research Institute, University of Southern California, Los Angeles, CA.
- Guangzhen, Sun. (1993) "Economic Impact of the Structural Changes of Production Technology: A Robust Approach," *Economic Systems Research*, 5 (3): 235-242
- Guimaraes, Paulo., Frank L. Hefner, and Douglas P. Woodward. (1993) "Wealth and Income Effects of Natural Disasters: an Econometric Analysis of Hurricane Hugo," *Review of Regional Studies*. 23: 97-114.
- Heesterman, A.R.G. (1990) "The Instability of the Dynamic Input-Output Model," *Economic Systems Research*, 2 (4): 351-355.

- Jackson, Randall W., and Moss Madden. (1999) "Closing the Case on Closure in Cole's Model," *Papers in Regional Science*. 78 (4): 423-427.
- Jackson, Randall W., Moss Madden, and Harry A. Bowman. (1997) "Closure in Cole's Reformulated Leontief Model," *Papers in Regional Science*. 76 (1): 21-28.
- Kawashima, Kazuhiko., Hideki Sugita, and Takashi Kanoh. (1991) "Estimation of Earthquake Induced Economic Damage." *Report of Public Works Research Institute* 186: 1-57. (in Japanese)
- Kuenne, R.E. (1963) *The Theory of General Economic Equilibrium*. Princeton, NJ: Princeton University Press.
- Leontief, Wassily. (1951) *The Structure of American Economy, 1919-1939. 2nd Edition*. New York: Oxford University Press.
- Leontief, Wassily. (1953) "Dynamic Analysis," in W. Leontief, H.B. Chenery, P.G. Clark, J.S. Duesenberry, A.R. Ferguson, A.P. Grosse, R.N. Grosse, and M. Holzman ed. *Studies in the Structure of the American Economy: Theoretical and Empirical Explorations in Input-Output Analysis*. New York, NY: Oxford University Press.
- Leontief, Wassily. (1970) "The Dynamic Inverse." in A. P. Carter and A. Brody eds. *Contributions to Input-Output Analysis*. Amsterdam, Netherlands: North-Holland Publishing; 17-46.
- Leontief, Wassily. and Faye Duchin. (1986) *The Future Impact of Automation on Workers*, New York, NY: Oxford University Press.
- Levine, Stephen H., and Eliahu Romanoff. (1989) "Economic Impacy Dynamics of Complex Engineering Project Scheduling, " *IEEE Transactions Systems, Man and Cybernetics*. 19: 232-240.
- Morishima, M. (1964) *Equilibrium, Stability and Growth*. Oxford: Clarendon Press.
- Mules, Trevor J. (1983) "Some Simulations with a Sequential Input-Output Model," *Papers of Regional Science Association*. 51: 197-204.
- National Academy of Sciences. (1978) *A Program of Studies in the Socioeconomic Effects of Earthquake Predictions*. Washington, D.C.: National Academy of Sciences.
- Okuyama, Yasuhide., Geoffrey J.D. Hewings, and Michael Sonis, (1999a) "Economic Impacts of an Unscheduled, Disruptive Event: A Miyazawa Multiplier Analysis," in Geoffrey J.D. Hewings, Michael Sonis, Moss Madden, and Yoshio Kimura eds. *Understanding and Interpreting Economic Structure*, Springer-Verlag: 113-144.
- Okuyama, Yasuhide., Geoffrey J.D. Hewings, and Michael Sonis (2001) "Economic Impacts of Unscheduled Events: Sequential Interindustry Model (SIM) Approach," Paper presented in the North American Meetings of Regional Science Association International, Charleston, SC.

- Okuyama, Yasuhide., Geoffrey J.D. Hewings, Tschangho J. Kim, David E. Boyce, Heejoo Ham, and Jungyul Sohn, (1999b) "Economic Impacts of an Earthquake in the New Madrid Seismic Zone: A Multiregional Analysis," in William M. Elliott and Peter McDonough eds. *Optimizing Post-Earthquake Lifeline System Reliability*, Technical Council on Lifeline Earthquake Engineering, Monograph No.16: 592-601.
- Oosterhaven, Jan. (2000) "Lessons from the Debate on Cole's Model Closure," *Papers in Regional Science*. 79 (2): 233-242.
- Romanoff, Eliahu. (1984) "Interindustry Analysis for Regional Growth and Development: The Dynamics of Manpower Issues." *Socio-Economic Planning Sciences* 18 (5): 353-363.
- Romanoff, Eliahu., and Stephen H. Levine. (1977) "Interregional Sequential Interindustry Modeling: A Preliminary Analysis of Regional Growth and Decline in a Two Region Case," *Northeast Regional Science Review*. 7: 87-101.
- Romanoff, Eliahu., and Stephen H. Levine. (1981) "Anticipatory and Responsive Sequential Interindustry Models" *IEEE Transactions on Systems, Man, and Cybernetics* SMC 11 (3): 181-186.
- Romanoff, Eliahu., and Stephen H. Levine. (1986) "Capacity Limitations, Inventory, and Time-Phased Production in the Sequential Interindustry Model." *Papers of the Regional Science Association* 59; 73-91.
- Romanoff, Eliahu., and Stephen H. Levine. (1990a) "Combined Regional Impact Dynamics of Several Construction Megaprojects," *Regional Science Review*. 17: 85-93.
- Romanoff, Eliahu., and Stephen H. Levine. (1990b) "Technical Change in Production Processes of the Sequential Interindustry Model." *Metroeconomica* 41 (1): 1-18.
- Romanoff, Eliahu., and Stephen H. Levine. (1991) "Technical Change and Regional Development: Some Further Developments with the Sequential Interindustry Model," in David E. Boyce, Peter Nijkamp, and D. Shafer eds. *Regional Science: Retrospect and Prospect*. Berlin: Springer-Verlag: 251-275.
- Romanoff, Eliahu., and Stephen H. Levine. (1993) "Information, Interindustry Dynamics, and the Service Industries" *Environmental and Planning A* 25: 305-316.
- Rose, Adam. and Juan Benavides (1998) "Regional Economic Impacts." in M. Shinozuka, A. Rose, and R.T. Eguchi eds. *Engineering and Socioeconomic Impacts of Earthquakes*. Buffalo, NY: Multidisciplinary Center for Earthquake Engineering Research: 95-123.
- Rose, Adam., Juan Benavides, Stephanie E. Chang, Philip Szczesniak, and Dongsoon Lim. (1997) "The Regional Economic Impact of an Earthquake: Direct and Indirect Effects of Electricity Lifeline Disruptions." *Journal of Regional Science* 37 (3): 437-458.
- Schinnar, Arie P. (1978) "The Leontief Generalized Inverse," *The Quarterly Journal of Economics*, 92 (4): 641-52

- Steenge, Albert E. (1990a) "On the Complete Instability of Empirically Implemented Dynamic Leontief Models," *Economic Systems Research*, 2 (1): 3-16
- Steenge, Albert E. (1990b) "Instability Problems in the Dynamic Leontief Model: an Economic Explanation," *Economic Systems Research*, 2 (4): 357-361.
- Szyld, Daniel B. (1985) "Conditions for the Existence of a Balanced Growth Solution for the Leontief Dynamic Input-Output Model," *Econometrica*, 53 (6): 1411-1419.
- ten Raa, Thijs. (1986) "Dynamic Input-Output Analysis with Distributed Activities," *Review of Economics and Statistics*. 68 (2): 300-310.
- West, Carol T. and David G. Lenze (1994) "Modeling the Regional Impact of Natural Disaster and Recovery: A General Framework and an Application to Hurricane Andrew." *International Regional Science Review* 17 (2): 121-150.
- Wilson, Robert. (1982) "Earthquake Vulnerability Analysis for Economic Impact Assessment." Washington D.C.: Information Resources Management Office, Federal Emergency Management Agency.
- Zaghini, Enrico. (1971) "Solow Prices and the Dual Stability Paradox in the Leontief Dynamic System," *Econometrica*, 39 (3): 625-632.

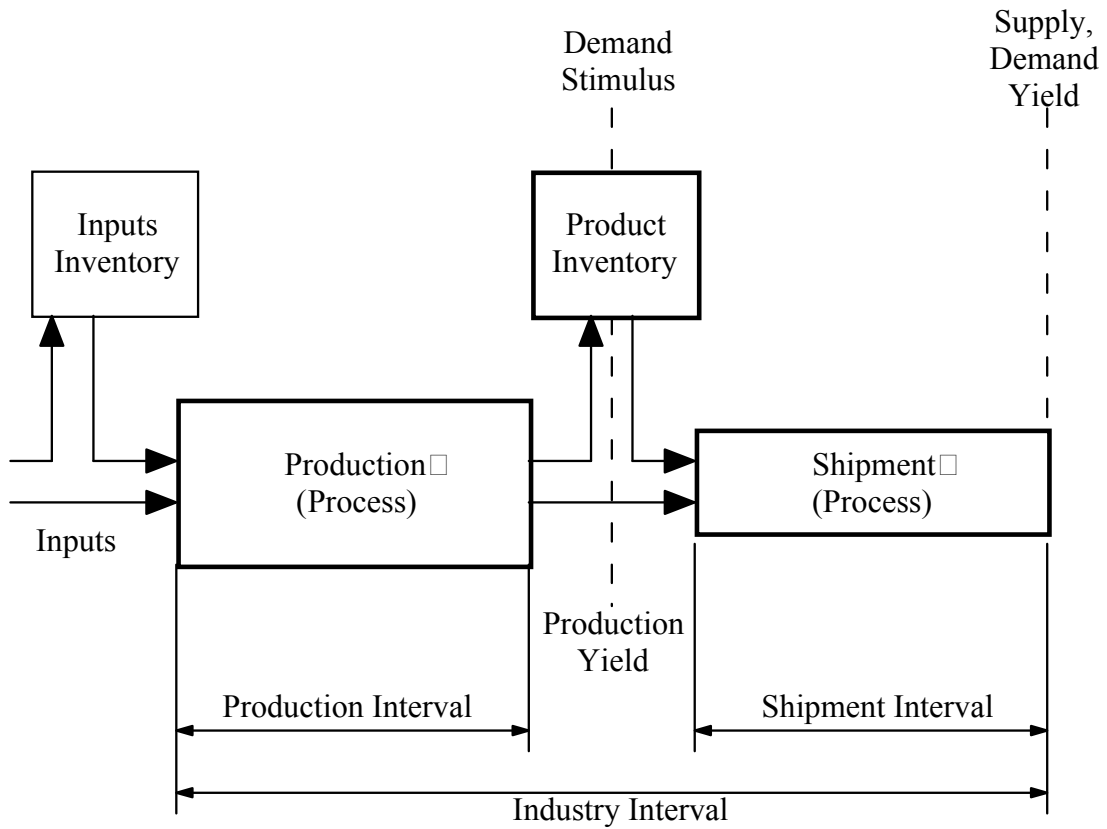

Figure 1. Production Interval (after Romanoff and Levine, 1981)

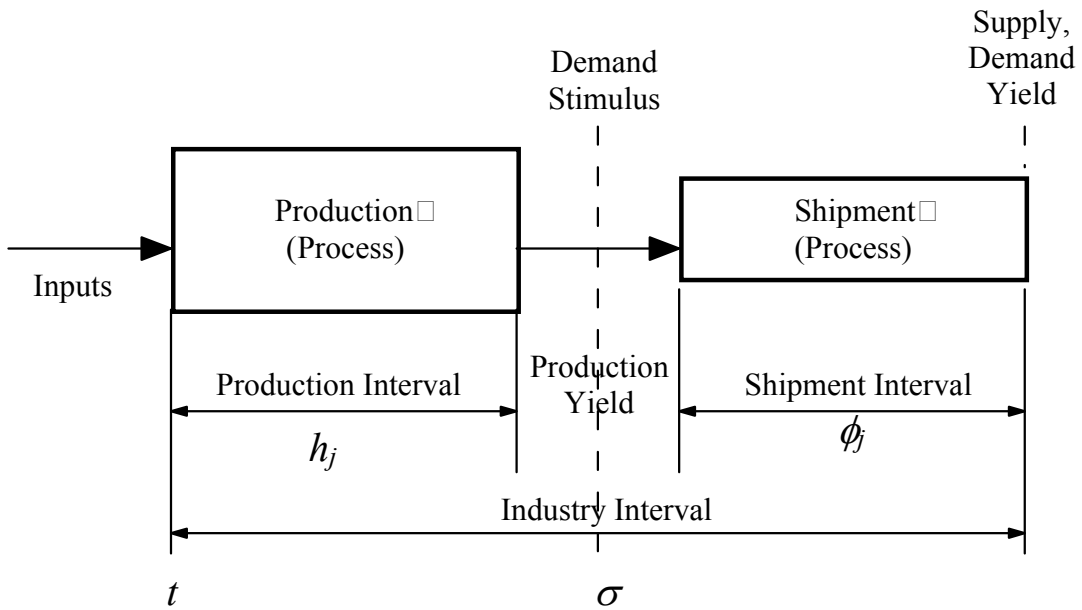

Figure 2. Production Interval with Time Indices

	1	2	3	w_i	y_i	x_i
1	0	4	2	6	2	8
2	0	0	6	6	6	12
3	0	0	0	0	16	16
u_j	0	4	8	12	24	36
v_j	8	8	8	24	0	24
x_j	8	12	16	36	24	

Figure 3. Transaction Table (Romanoff, 1984)

Table 1. Final Demand Schedule with a Catastrophic Disaster at Period 5 period

	1	2	3	4	5	6	7	8	9	10	11	12	13
y_1	2	2	2	2	1.60	1.65	1.70	1.75	1.80	1.85	1.91	1.97	2.03
y_2	6	6	6	6	4.80	4.94	5.09	5.25	5.40	5.56	5.73	5.90	6.08
y_3	16	16	16	16	12.80	13.18	13.85	13.99	14.41	14.84	15.28	15.74	16.21
total	24	24	24	24	19.20	19.78	20.37	20.98	21.61	22.26	22.93	23.61	24.32

Table 2. Output Level based on Anticipated Demand Period

	1	2	3	4	5	6	7	8	9	10
x_1	8	8	8	8	6.59	6.94	7.20	7.42	7.64	7.87
x_2	12	12	12	12	9.89	10.34	10.65	10.97	11.3	11.63
x_3	16	16	16	16	13.18	13.58	13.99	14.41	14.84	15.28
total	36	36	36	36	29.66	30.86	31.84	32.79	33.78	34.79

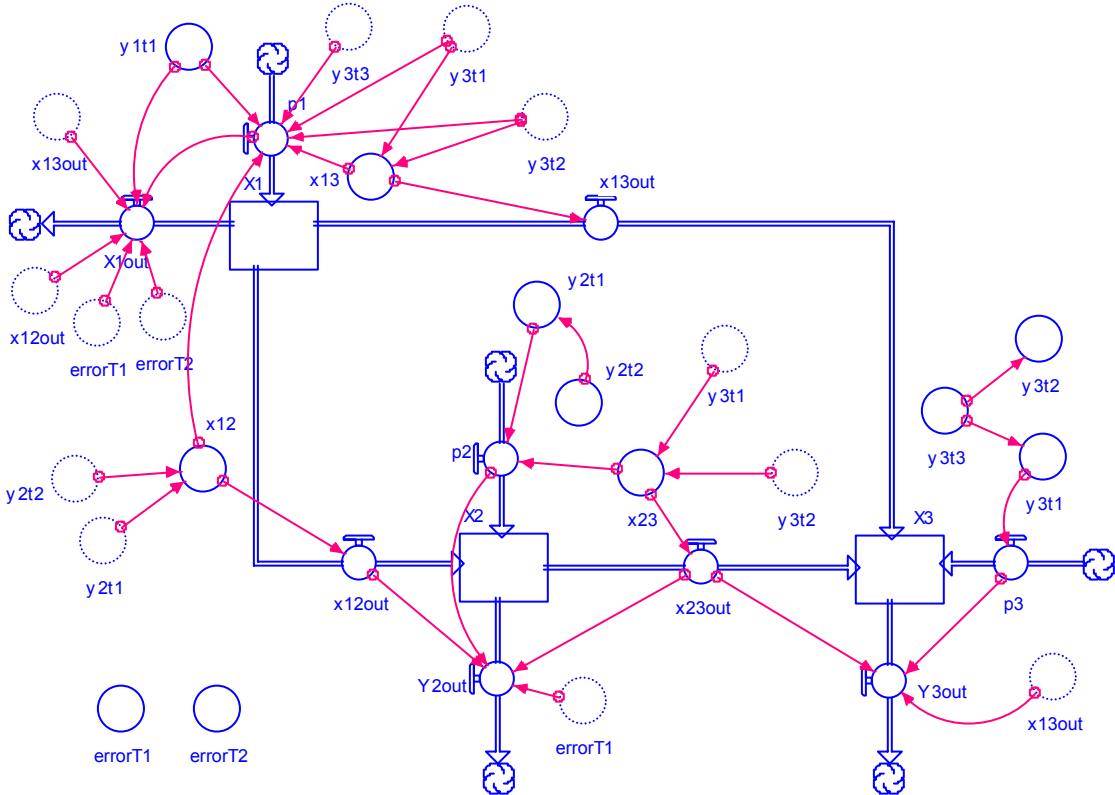

Figure 4. Diagram of Example Model with Inventory

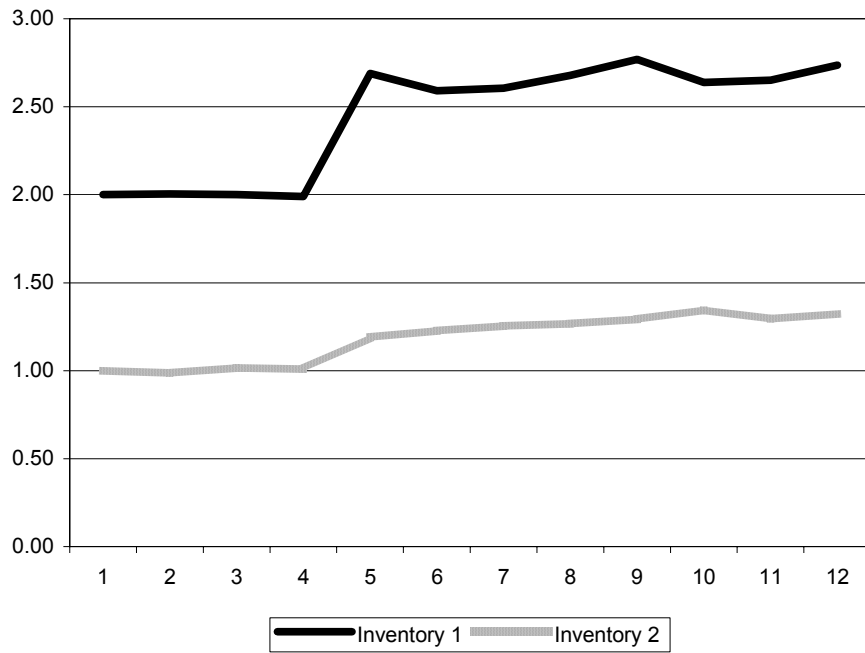

Figure 5. Trends of Inventory Level under Scenario A

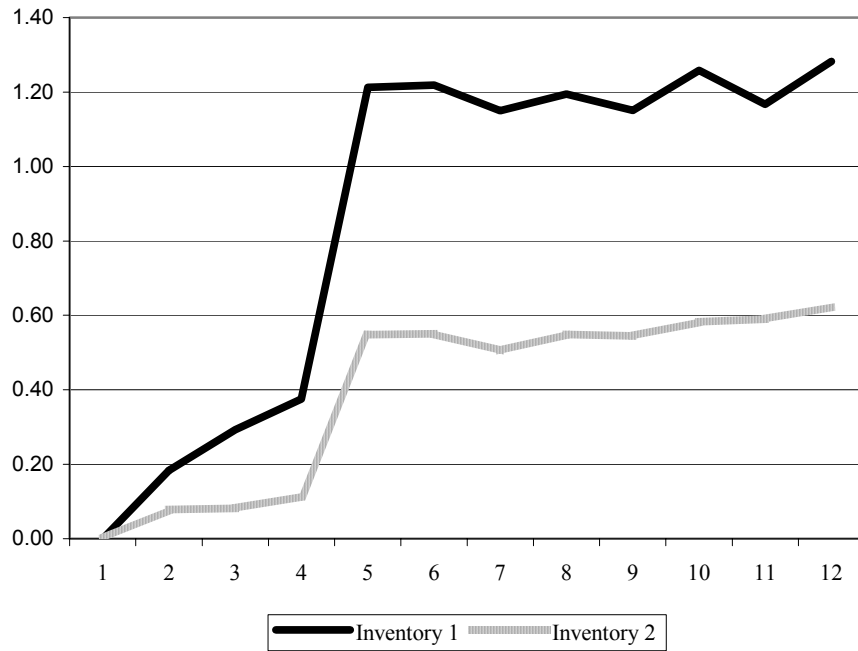

Figure 6. Trends of Standard Deviation of Inventory Level under Scenario A

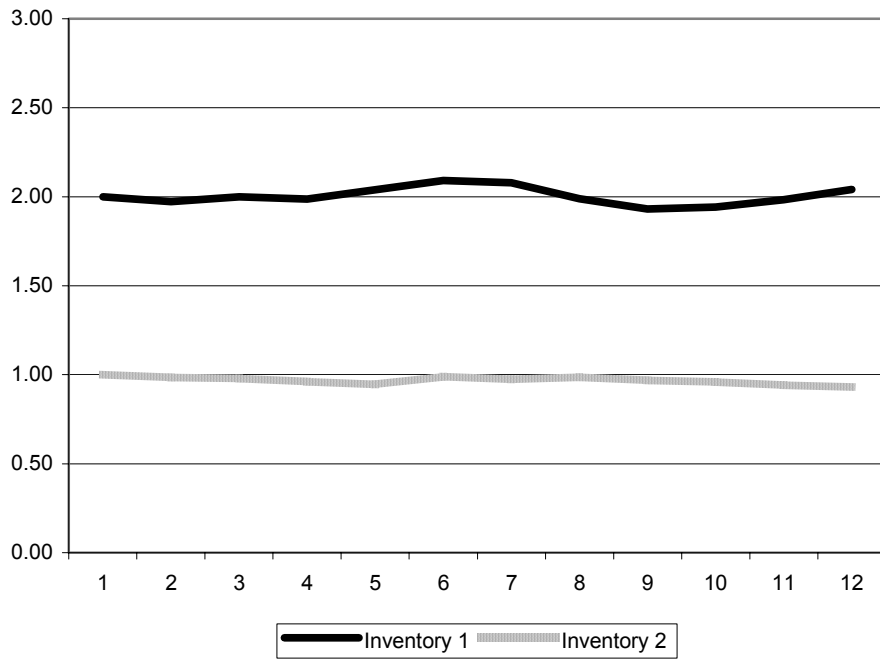

Figure 7. Trends of Inventory Level under Scenario B

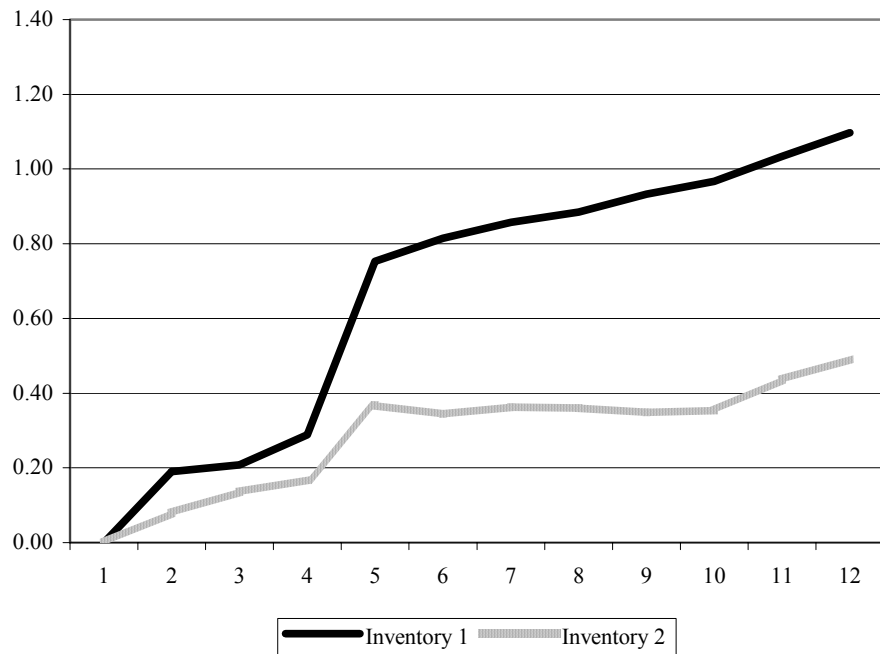

Figure 8. Trends of Standard Deviation of Inventory Level under Scenario B

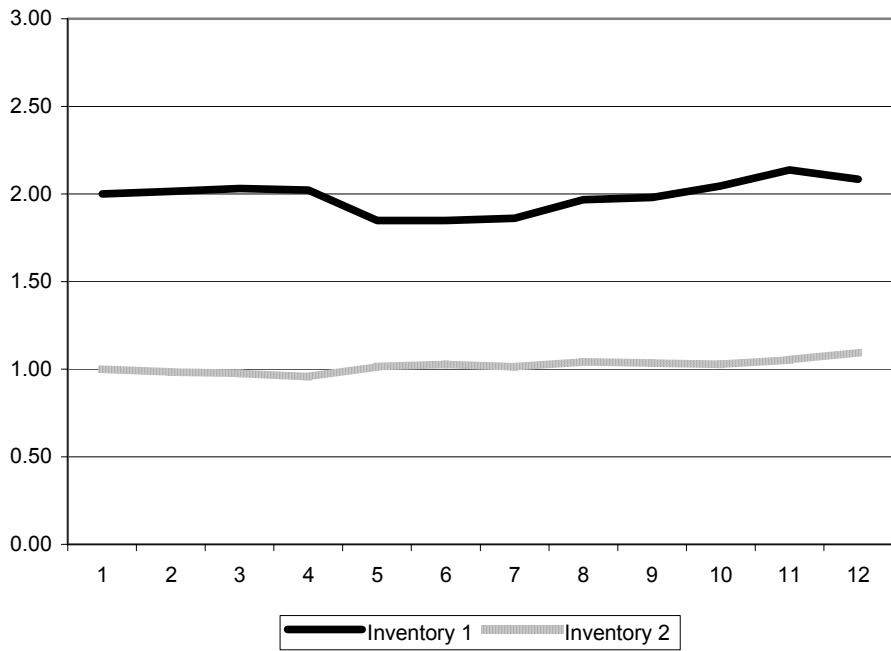

Figure 9. Trends of Inventory Level under Scenario C

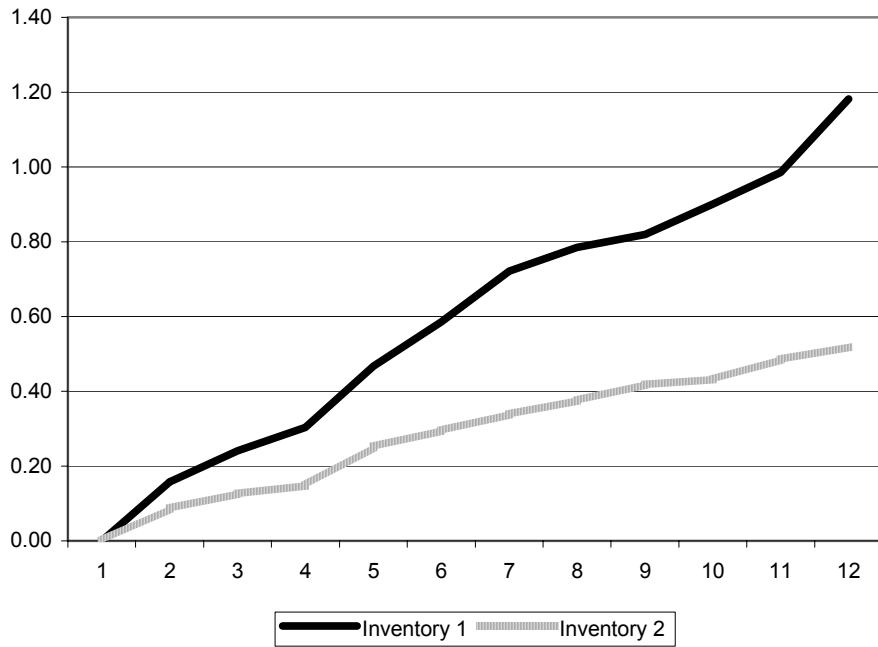
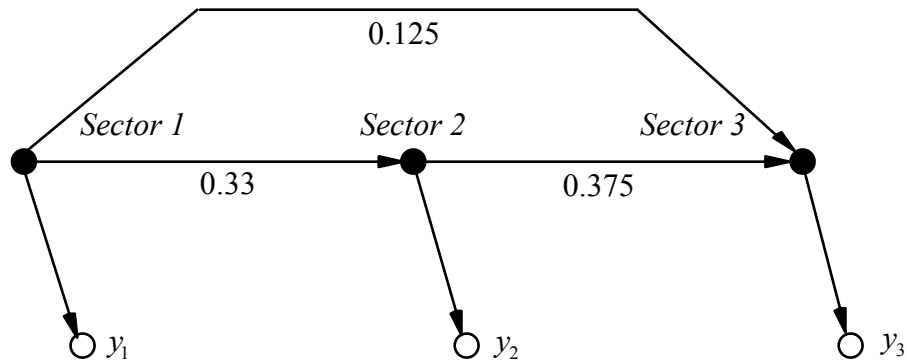

Figure 10. Trends of Standard Deviation of Inventory Level under Scenario C

Appendix

$$\mathbf{A} = \begin{bmatrix} 0 & 0.33 & 0.125 \\ 0 & 0 & 0.375 \\ 0 & 0 & 0 \end{bmatrix} \quad (\mathbf{I} - \mathbf{A})^{-1} = \begin{bmatrix} 1.0 & 0.33 & 0.25 \\ 0 & 1.0 & 0.375 \\ 0 & 0 & 1.0 \end{bmatrix}$$

A-1. Direct Input Coefficient Matrix (A) and its Leontief Inverse (Romanoff, 1984)



A-2. Production Digraph (Romanoff, 1984)